

Catharine Township Municipality

1229 Recreation Drive, Williamsburg, PA 16693
Email: catharinetownship@yahoo.com

Phone: 814.832.3851
Website: catharinetownship.org

Required checklist to obtain a building permit for:

DECK

- Complete 2 page Application for Building Permit/Use Certificate
- Land Use Permit (signed and approved by Municipality)
- Set of building plans (footer, framing, floor plan, cross section, etc)
- Site plans (include all existing structures, proposed structure and their distances to all lot lines)
- Worker's Compensation Insurance Coverage Information Form
- Driving instructions

CCIS Permit: Under 30" high and adding a roof, Over 30" high with or without roof, replacing a roof over a deck regardless of height, replacing a floor of a deck regardless of height, enclosing a deck with walls regardless of height

Township Permit: Under 30" high with no roof

Railings are required for decks over 30" high

Handrails are required for stairs of a deck if four or more risers are used

- ⇒ After submitting all required documents your application will be reviewed.
- ⇒ CCIS will contact you to let you know if your application has been approved or denied (if applicable).
- ⇒ When the project is approved you will be notified the Building Permit is ready. Prior to obtaining the building permit all charges (i.e. municipality, administrative, inspection fees...) must be paid.
- ⇒ Be advised additional fees may be applied throughout the project for failed or missed inspections.

APPLICATION FOR BUILDING PERMIT / USE CERTIFICATE

Permit Number: _____

Property / Site Information

Site Address: _____
Complete address/City/State/Zip

Municipality: _____ County: _____ Tax Map #: _____

Use: Residential ___Single-Family dwelling ___Multi-Family ___New ___Manufactured/Modular Home

Commercial ___Other _____ Floodplain present: Yes No

Improvement Type: New Addition Alteration Repair/replacement Relocation

Other _____

Land / Property Owner's Information

First Name _____ MI. _____ Last Name _____ Phone# _____ Cell# _____

Street Address _____ City _____ State _____ Zip _____ Email _____

Building Permit Application

Provide a description of work below: *(Also provide details on plot plan: Show all improvements on lot & approximate distances to lot lines)*

Estimated Cost of Construction \$ _____

Estimated start date _____ Estimated completion date _____

Contractor Information

Name of Contractor: _____ Phone# _____

Person in charge of work: _____ Phone# _____

Address of Contractor _____
Address/City/State/Zip

Proof of Worker's Compensation Insurance: Provided Exempt

Subcontractor Information

Name _____ Address/City/State/Zip _____ Phone# _____

Name _____ Address/City/State/Zip _____ Phone# _____

Project Details

Trades: Building Electrical Work Plumbing Work Mechanical Work (HVAC)

Fire Suppression/Alarm System

Heat Source: _____ Fuel Type: _____

Foundation Type: Crawlspace Foundation Slab at Grade Piers Other _____

Details: _____

Certification

I certify that I am the owner of record, or that I have been authorized by the owner of record to submit this application and that the work described has been authorized by the owner of record. I understand and assume responsibility for the establishment of official property lines for required setbacks prior to the start of construction, and agree to conform to all applicable local, state, and federal laws governing the execution of this project. I certify that the Code Official or his/her representative shall have the authority to enter the areas in which work is being performed, at any reasonable hour, to enforce the provisions of the Codes governing this project. I further certify that this information is true and correct to the best of my knowledge and belief.

Applicant Signature _____ Print Name _____ Date _____

Applicant Phone# (Land line and Cell) _____ Email _____

Applicant Complete Address/City/State/Zip _____

OFFICE USE:	
Application fee \$ _____	Issuance Date ____/____/____
Permit Fee \$ _____	Expiration Date ____/____/____
Inspection Fees \$ _____	Extension Date ____/____/____
APPLICATION STATUS: <input type="checkbox"/> GRANTED <input type="checkbox"/> DENIED	
_____ Signature of Permit Officer	_____ Date
	{SEAL}

Land Use Permit Checklist

NOTE TO APPLICANT: Applicable items on this checklist shall be completed prior to your submission of an application for a building permit. Failure to complete any applicable item on this checklist shall be sufficient grounds for denial of the building permit application. Please contact your local municipal office or the local Commonwealth Code Inspection Service, Inc. office if you have any questions about the process for obtaining a building permit.

Municipality: Catharine Township County: Blair

Land Use Permit #: _____ Tax map location: _____

Work site address: _____

Contact person: _____ Phone: _____

Address: _____

Type of Construction (describe): _____

New Additions Alteration Repair/Replacement Relocation Other _____

Estimated Start Date: _____ Estimated Completion Date: _____

Estimated cost/value of construction: \$ _____

I certify that I am the owner of record, or that I have been authorized by the owner of record to submit this application and that the work described has been authorized by the owner of record, and I agree to conform to all applicable local, state, and federal laws governing the execution of this project. I certify that the Code Official or his representative shall have the authority to enter the areas in which this work is being performed, at any reasonable hour, to enforce the provisions of the Codes governing this project. I understand and assume responsibility for the establishment of official property lines for required setbacks prior to the start of construction, and agree to conform to all applicable laws of this jurisdiction. I further certify that this information is true and correct to the best of my knowledge.

Applicant's signature _____ Date _____

Checklist of preliminary requirements for obtaining a building permit, approvals to be obtained prior to applying for a building permit. All items must be addressed. Mark N/A for those that are not applicable. Attach extra sheets if necessary to identify special requirements or conditions.

- | | <u>Date of Approval</u> |
|---|-------------------------|
| <input type="checkbox"/> Sewage facilities planning module, DEP Planning Code # _____ | _____ |
| <input type="checkbox"/> Sub-division & Land Development, Municipal Resolution # _____ | _____ |
| <input type="checkbox"/> Sewage permit from Sewage Enforcement Officer, Permit # _____ | _____ |
| <input type="checkbox"/> Storm water management module. Approved by _____ | _____ |
| <input type="checkbox"/> Conservation District notification per Chapter 102 | _____ |
| <input type="checkbox"/> NPDES Permit # _____ for earth disturbances 1 acre or more | _____ |
| <input type="checkbox"/> Driveway permit, PennDot # _____ or Local # _____ | _____ |
| <input type="checkbox"/> Public water tap, Permit # _____ | _____ |
| <input type="checkbox"/> Public sewage tap, Permit # _____ | _____ |
| <input type="checkbox"/> Historical Architectural Review Board, ____ Check here for special conditions | _____ |
| <input type="checkbox"/> Other; slue pipe, road alteration, etc. ____ Check here for special conditions | _____ |
| <input type="checkbox"/> Floodplain mapping. Project may contain flood plain, ____ | _____ |
| <input type="checkbox"/> Municipal setback clearances, ____ Check here for special conditions | _____ |
| <input type="checkbox"/> Extra pages attached to describe special conditions or circumstance. There are ____ extra pages. | _____ |

Approved-Municipal Official's Signature & title _____ Date _____

{SEAL}

This signature indicates Municipal verification & approval of the Land Use Project as described along with approval of all items on the Checklist.

SITE PLAN

EXAMPLE

Show any other existing structures on the property (pool, patio, deck, etc.)

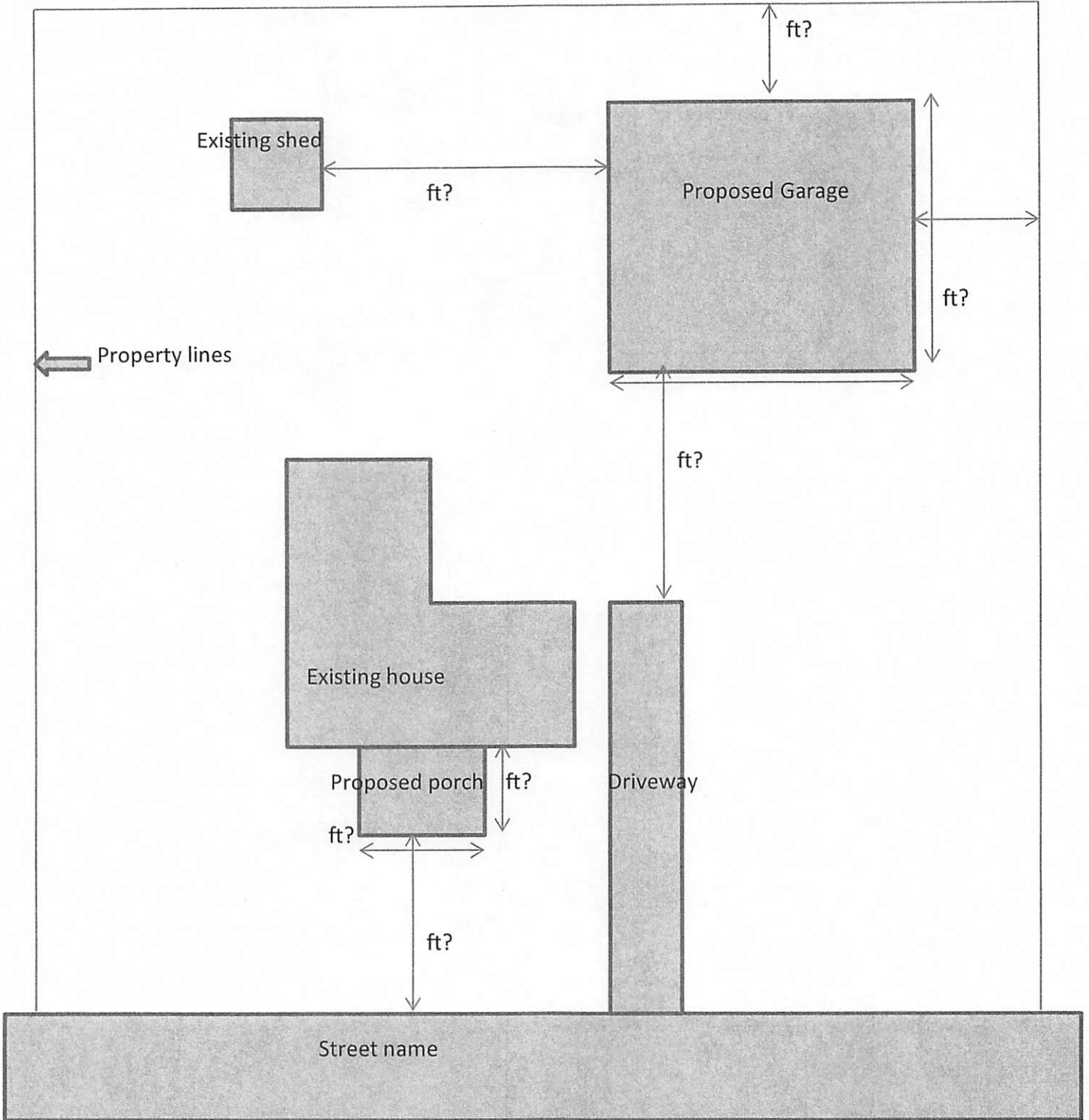

SITE PLAN

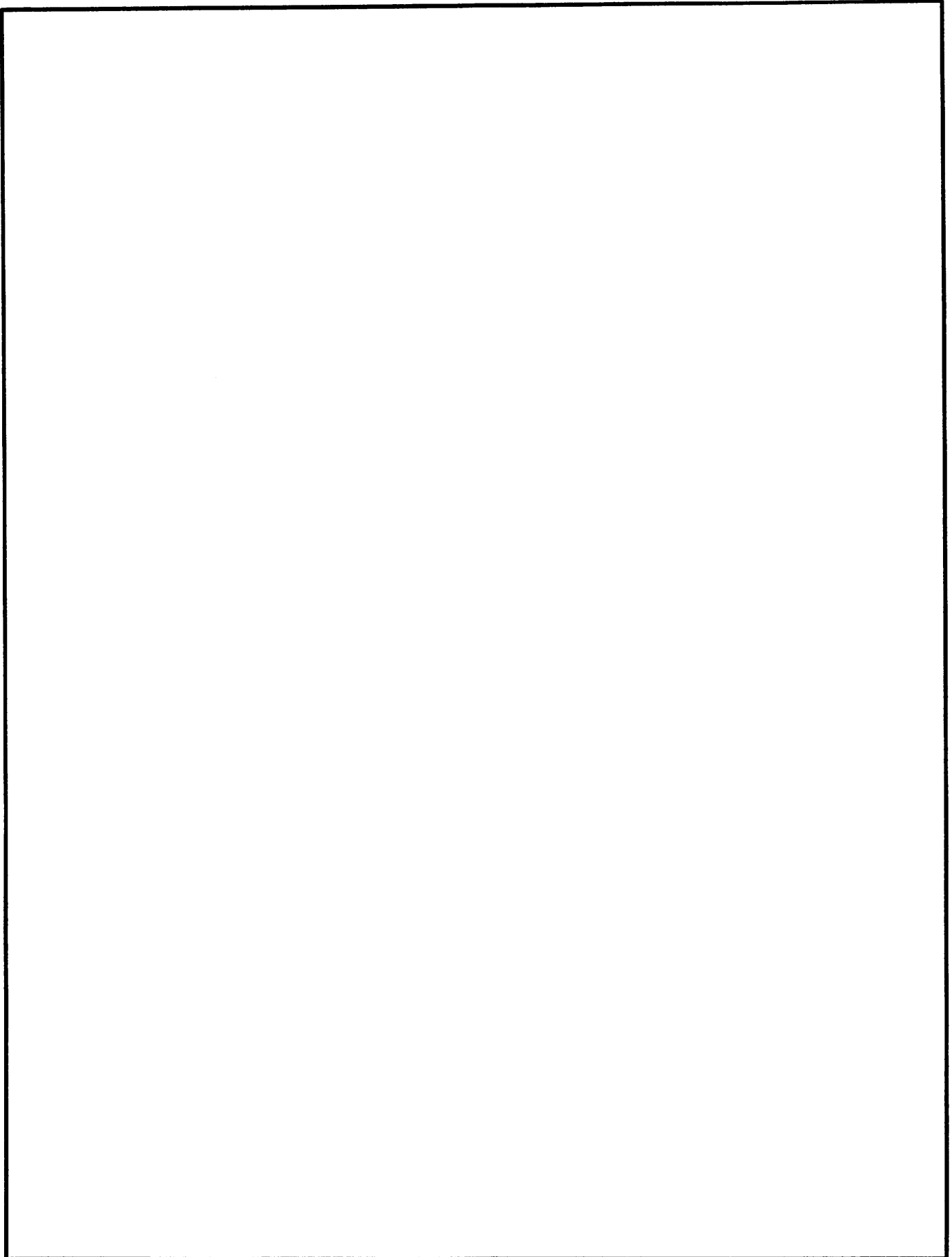

Worker's Compensation Insurance Coverage Information

A. The applicant is a contractor within the meaning of Pennsylvania Workers' Compensation Law.
 YES NO

If the answer is YES, complete Section B. If there is an exemption, then complete Section C below.
If the answer is NO, complete Section C below.

B. Insurance Information:

Name of Applicant: _____

Federal or State Employer Identification No. _____

Applicant is a qualified self-insurer for Workers' Compensation

Original Certificate attached

Name of Workers' Compensation insurer _____

Workers' Compensation Insurance Policy No. _____

Original Certificate attached

Policy Expiration Date _____

C. Exemption: MUST BE NOTORIZED

Complete this section if the applicant is a contractor or homeowner claiming exemption from providing workers' compensation insurance. The undersigned swears or affirms that he/she is not required to provide workers' compensation insurance under the provisions of Pennsylvania's Worker's Compensation Law for one of the following reasons, as indicated.

Contractor with no employees. Contractor prohibited by law from employing any individual to perform work pursuant to this building permit unless contractor provides proof of insurance to Municipality.

Homeowner who elects to perform all of the work without contracting or hiring others to assist.

Religious exemption under Workers' Compensation Law

Signature of Applicant: _____ Date: _____

Address: _____

Commonwealth of Pennsylvania

County of _____

On this, the _____ day of _____, 20____, before me _____ the undersigned officer, personally appeared _____, known to me (or satisfactorily proven) to be the person whose name subscribed to the within instrument, and acknowledged that he/she executed the same for the purposes therein contained.

In witness whereof, I hereunto set my hand and official seal.

Notary Public

DIRECTIONS TO THE SITE LOCATION

Fill out completely

Name of Owner: _____

Phone Number: _____

Address of project: _____

Directions:

*Please note directions should be clear so inspectors can find the address with no difficulties. Use Street names, landmarks, direction of travel, turn off distance, etc...

Use space below if needed to further clarify the site location:

Deck Plan w/ Roof Submittal

Drawings and Details

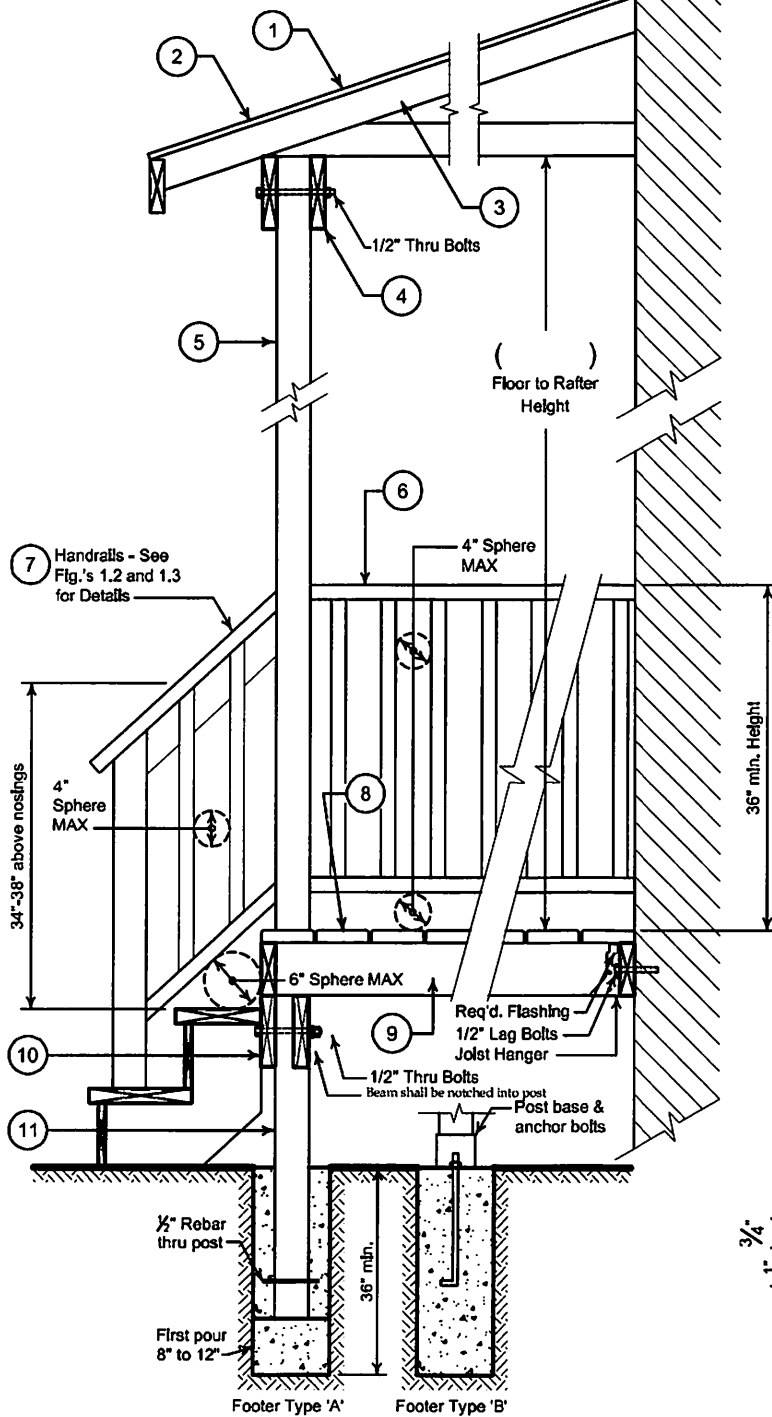

Typical Section
Figure 1.1

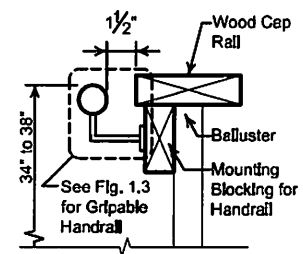

Handrail Details
Figure 1.2

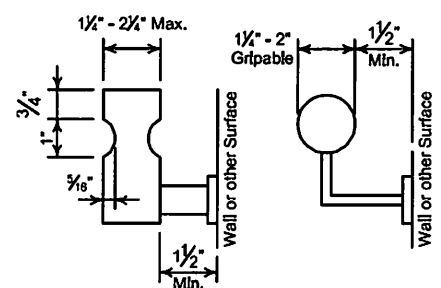

Acceptable Handrail Grips
Figure 1.3

Deck Plan w/ Roof Submittal

- Provide Plans for Roof (looking down from above) and Plan of Deck, indicate Existing Structure, and New Construction. All drawings must include types, sizes and spans of all materials used such as Posts, Beams, Joists, Trusses and Rafters.
- See Drawings and Details Figures 1.1, 1.2 and 1.3 for Item locations and additional information.

Roof Type:

- Select one: Shed___ Gable___ Hip___ Other___

Roof Size (overall dimensions):

- Length:_____ Width:_____

① Roof Covering:

- Type:_____

② Roof Sheathing:

- Type:_____ Thickness:_____

③ Rafters or Trusses: (circle one)

- Type:_____ Pitch:_____
- Span:_____ Spacing:_____

④ Carrier Beam (roof):

- Material:_____
- Size (nominal):_____ X _____
- Spacing Center to Center:_____
- Clear span distance:_____

⑤ Support Post (roof):

(n/a if post runs thru to footer)

- Material:_____
- Size (nominal):_____ X _____
- Post Length:_____

⑥ Guardrail:

- Required if floor is 30" or more above ground.
- Constructed so no opening will allow 4" sphere to pass thru.
- * See note

Stairs (where applicable):

- No. of Treads (9" min.): _____
- No. Risers (8 $\frac{1}{4}$ " max.): _____
- Min. 4" high toe Kick.

⑦ Handrail:

- Constructed so no opening will allow 4" sphere to pass thru.
- See Figure 1.2 for Acceptable Handrail Details
- * See note

Deck Size (overall dimensions):

- All Fasteners MUST be exterior grade.
- Length:_____ Width:_____

⑧ Flooring:

- Material:_____
- Size (nominal):_____ X _____

⑨ Floor Joists:

- Material:_____
- Size (nominal):_____ X _____
- Spacing Center to Center:_____
- Clear span distance:_____

⑩ Carrier Beam (floor):

- Material:_____
- Size (nominal):_____ X _____
- Spacing Center to Center:_____
- Clear span distance:_____

⑪ Support Post (deck):

- Material:_____
- Size (nominal):_____ X _____
- Post Length:_____

Footer:

(Select one or provide drawing if other)

- Type 'A': _____
- Type 'B': _____

*Note:

- Handrail assemblies and guards shall be able to resist a single concentrated load of 200lbs. applied in any direction at any point along the top.

DECK PLAN WITH CANTILEVER

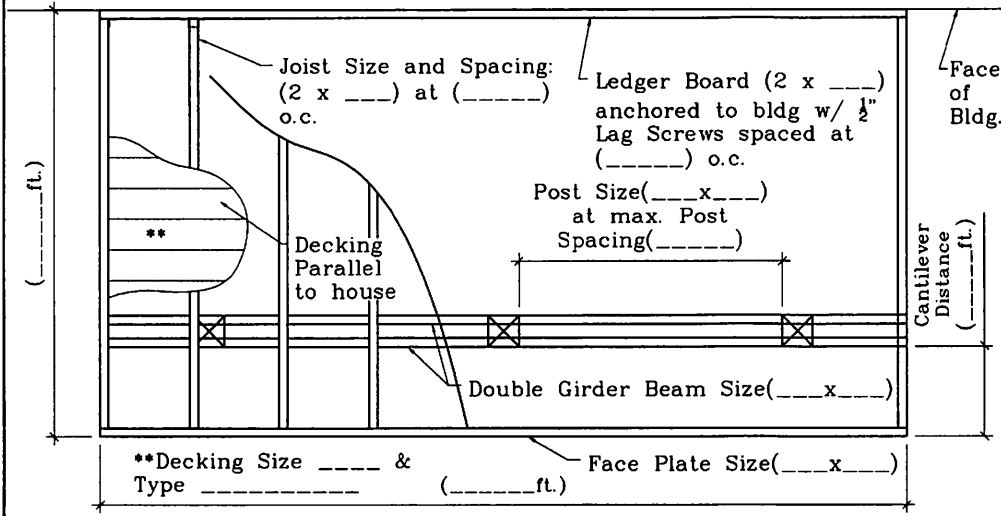

DECK PLAN WITHOUT CANTILEVER

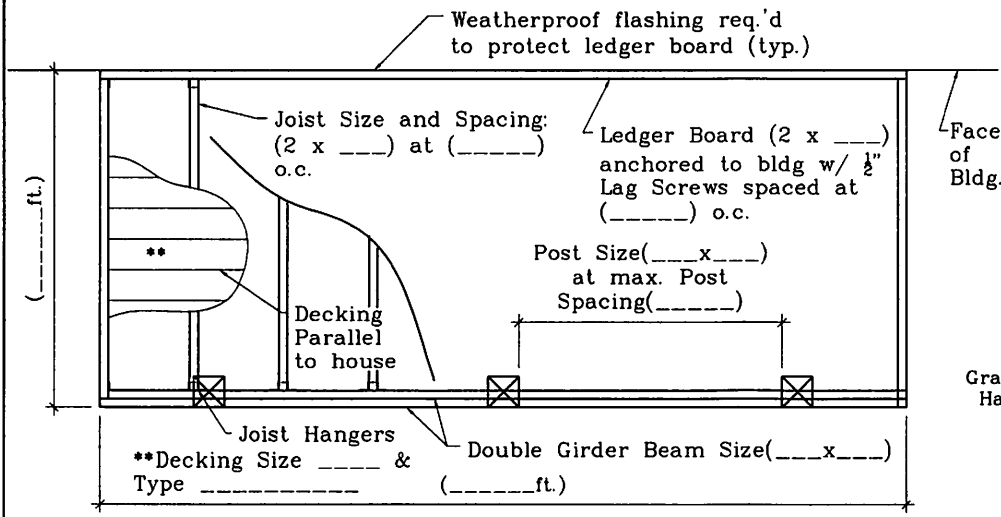

DECK PLAN WITH DECKING PERPENDICULAR TO HOUSE

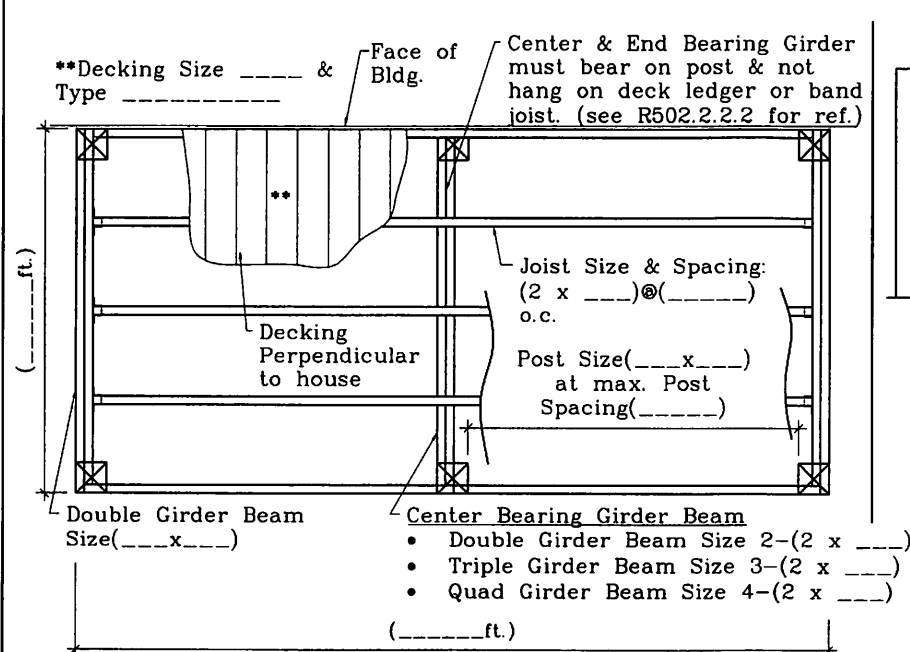

GRASPABLE HANDRAIL DETAILS

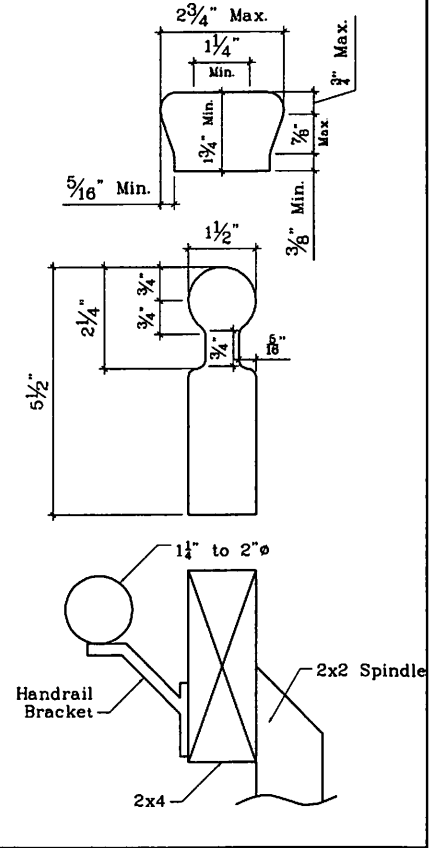

TYPICAL PORCH & LANDING SECTION

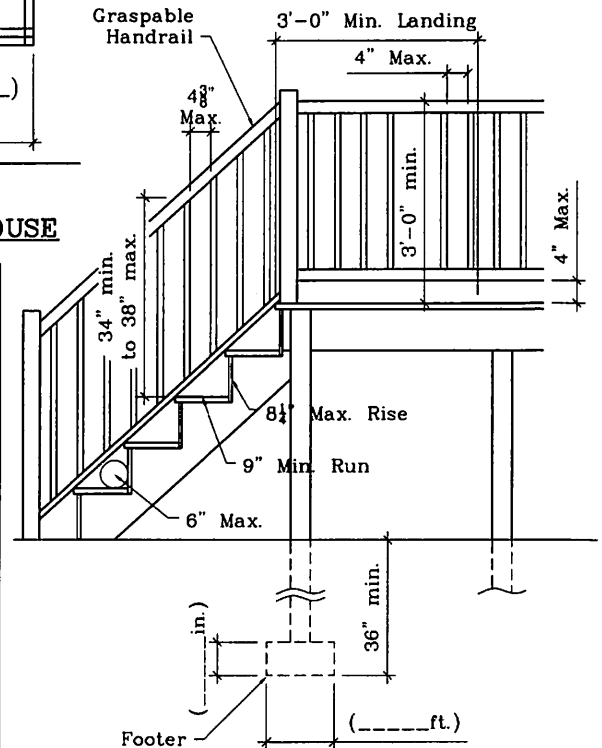

DECK DETAILS

Date: 11-14-14 Revised: